

CA SERIES POWER AMPLIFIERS

MODELS: CA2250/CA2500/CA4250/ CA6160/CA8125

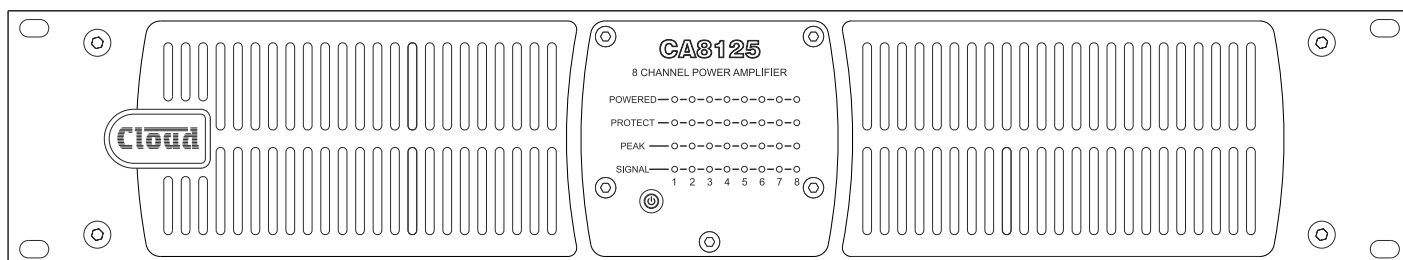

<https://muzcentre.ru>





Installation and User Guide

WARNING:

To reduce the risk of fire or electric shock, do not expose this appliance to rain or moisture.

CAUTION:

	<p>WARNING: SHOCK HAZARD – DO NOT OPEN AVIS: RISQUE DE CHOC ÉLECTRIQUE – NE PAS OUVRIR</p>
	<p>The lightning flash with the arrowhead symbol within an equilateral triangle, is intended to alert you to the presence of uninsulated dangerous voltages within the product’s enclosure that may be of sufficient magnitude to constitute a risk of electric shock.</p>
	<p>The exclamation point within an equilateral triangle is intended to alert the user to the presence of important operating and maintenance (servicing) instructions in the literature accompanying the appliance.</p>

IMPORTANT SAFETY INSTRUCTIONS

1. Read these Instructions.
2. Keep these Instructions.
3. Heed all Warnings.
4. Follow all Instructions.
5. Do not use this apparatus near water.
6. Clean only with a dry cloth.
7. Do not block any ventilation openings. Install in accordance with the manufacturers' instructions.
8. Do not install near any heat sources such as radiators, heat registers, stoves or other apparatus (including amplifiers) that produce heat.
9. Do not defeat the safety purpose of the polarized or grounding - type plug. A polarized plug has two blades with one wider than the other. A grounding type plug has two blades and a third grounding prong. The wide blade or the third prong are provided for your safety. When the provided plug does not fit into your outlet, consult an electrician for replacement of the obsolete outlet.
10. Protect the power cord from being walked on or pinched particularly at plugs, convenience receptacles, and the point where they exit from the apparatus.
11. Only use attachments/accessories specified by the manufacturer.
12.  Use only with the cart, stand, tripod, bracket or table specified by the manufacturer or sold with the apparatus, when a cart is used, use caution when moving the cart/apparatus combination to avoid injury from tip-over.
13. Unplug this apparatus during lightning storms or when unused for long periods of time.
14. Refer all servicing to qualified service personnel. Servicing is required when the apparatus has been damaged in any way, such as power-supply cord or plug is damaged, liquid has been spilled or objects have fallen into the apparatus, the apparatus has been exposed to rain or moisture, does not operate normally, or has been dropped.



Do not expose the apparatus to dripping or splashing, and ensure that no objects filled with water, such as vases, are placed on the apparatus.

L'appareil ne doit être exposé aux écoulements ou aux éclaboussures et aucun objet ne contenant de liquide, tel qu'un vase, ne doit être placé sur l'appareil.



The mains plug is used as the disconnect device and it should remain readily accessible during intended use. In order to isolate the apparatus from the mains, the mains plug should be completely removed from the mains outlet socket.

Le prise du secteur ne doit pas être obstruée ou doit être facilement accessible pendant son utilisation. Pour être complètement déconnecté de l'alimentation d'entrée, la prise doit être débranchée du secteur.

Contents

SAFETY INFORMATION.....	6
Safety notes regarding installation.....	6
Conformities.....	6
Safety Considerations and Information	6
High Voltage	6
Mains Fuse	6
Servicing	6
Overview.....	7
Introduction	7
Applicable Models.....	7
CA Series amplifiers - main features.....	8
What's in the Box.....	8
Block Diagram.....	8
Front Panel Description	9
Rear Panel Description.....	10
Installation.....	11
Mechanical	11
Ventilation.....	11
Power requirements and turning the amplifier on and off	11
Remote Power Down	11
Amplifier Protection.....	11
Power sharing (high impedance output mode only).....	12
Connections and Adjustments	13
Inputs	13
Input Routing.....	13
Outputs	15
70/100 V-line operation.....	15
Low impedance operation.....	16
Level Control.....	16
Technical Specifications	17

SAFETY INFORMATION

Safety notes regarding installation

- Do not expose the unit to water or moisture.
- Do not expose the unit to naked flames.
- Do not block or restrict any air vent.
- Do not operate the unit in ambient temperatures above 35 °C.
- Do not touch any part or terminal carrying the hazardous live symbol ⚡ while power is supplied to the unit.
- Do not perform any internal adjustments unless you are qualified to do so and fully understand the hazards associated with mains operated equipment.
- The unit has no user serviceable parts. Refer any servicing to qualified service personnel.
- If the moulded plug is cut off the AC power lead for any reason, the discarded plug is a potential hazard and should be disposed of in a responsible manner.

Safety Considerations and Information

All models in the Cloud CA amplifier range must be earthed. Ensure that the mains power supply provides an effective earth connection using a three-wire termination.

Caution – High Voltage

Do not touch any part or terminal carrying the hazardous live symbol while power is applied to the unit. Terminals to which the hazardous live symbol refers require installation by a qualified person.

Caution – Mains Fuse

CA Series amplifiers contain no user-replaceable fuses.

Caution – Servicing

The unit contains no user-serviceable parts. Refer servicing to qualified personnel. Do not perform servicing unless you are qualified to do so. Disconnect the power cable from the unit before removing the top panel and do not make any internal adjustments with the unit switched on. Only reassemble the unit using bolts/screws identical to the original parts.

Conformities

This product conforms to the following European EMC Standards:

BS EN 55035:2017 (Immunity)

BS EN 55032:2015 (Emissions)

BS EN 61000-3-2:2014 (Harmonics)

BS EN 61000-3-3:2013 (Flicker)

This product has been tested for use in commercial and light industrial environments. If the equipment is used in controlled EMC environments, the urban outdoors, heavy industrial environments or close to railways, transmitters, overhead power lines etc. the performance of the unit may be degraded.

This product conforms to the following electrical safety standard:

BS EN 62368-1:2014

RoHS and WEEE declaration

Cloud Electronics Limited manages its business and collaborates with its suppliers to comply with the European Union restriction of the use of certain hazardous substances in electrical and electronic equipment, RoHS Directive (2002/95/EC), that came into force on 1st July 2006, and similar restrictions in other jurisdictions.



The "crossed out wheellie bin" symbol on the product and represented above is there to remind users of the obligation of selective collection of waste. This label is applied to various products to indicate that the product is not to be thrown away as unsorted municipal waste. At the end of life, dispose of this product by returning it to the point of sale or to your local municipal collection point for recycling of electric and electronic devices.

Customer participation is important to minimize the potential effects on the environment and human health that can result from hazardous substances that may be contained in this product.

Please dispose of this product and its packaging in accordance with local and national disposal regulations, including those governing the recovery and recycling of waste electrical and electronic equipment. Contact your local waste administration, waste collection company or dealer.

Overview

Introduction

The Cloud CA Series is a range of versatile multi-channel audio power amplifiers of advanced design, able to drive low impedance loudspeakers, or high impedance (100 V-line or 70 V-line) loudspeaker distribution systems directly. They are ideal for sound reinforcement applications in the retail, leisure, hospitality, commercial or industrial sectors.

Models CA2500, CA4250, CA6160 and CA8125 are capable of delivering 1 kW of audio power. In high impedance (70/100 V-line) mode, this maximum power rating can be shared between channels in an intelligent manner, allowing the amplifiers to drive different types or numbers of loudspeakers in the various areas of a building or venue with maximum economy. Model CA2250 can deliver a maximum of 500 W of audio power, which may be similarly shared between its two channels.

The range comprises five models which, with the exception of Model CA2250, differ only in the number of channels. The figure in the "POWER" column below represents the power that can be delivered to a four or eight ohm load when all channels are equally driven:

MODEL	CHANNELS	POWER
CA2250	2	2 X 250 W
CA2500	2	2 X 500 W
CA4250	4	4 X 250 W
CA6160	6	6 X 160 W
CA8125	8	8 x 125 W

Particular design attention has been paid to the amplifiers' energy efficiency. The Class D output stages dispense with line output transformers, and consequently offer great savings in weight and size over earlier designs. An automatic, two-stage power-down feature (APD) mutes the amplifier if no input signal has been detected for 15 minutes, and then enters an ultra-low-current standby mode if no input signal has been detected for 25 minutes; in this latter mode the power consumption is less than 2.5 W. The amplifiers also include a remote standby/wake up function, enabling them to be placed into standby mode - and subsequently powered-up again - by a simple external contact closure. The APD feature can be disabled by a rear panel DIP switch.

Safety features of the design include output DC detection, overcurrent protection, and thermal monitoring. A switch-on delay provides loudspeaker protection at power-up. All models use variable-speed forced-air cooling.

Applicable Models

This Installation Guide describes the installation and operation of the following models:

- Cloud CA2250: 2-channel amplifier, low impedance and 70/100 V-line outputs, total rating 500 W
- Cloud CA2500: 2-channel amplifier, low impedance and 70/100 V-line outputs, total rating 1 kW
- Cloud CA4250: 4-channel amplifier, low impedance and 70/100 V-line outputs, total rating 1 kW
- Cloud CA6160: 6-channel amplifier, low impedance and 70/100 V-line outputs, total rating 1 kW
- Cloud CA8125: 8-channel amplifier, low impedance and 70/100 V-line outputs, total rating 1 kW

Wherever the term "CA Series amplifier" or simply "amplifier" is used in this manual, it may be assumed that the information is applicable to all the above models. Where information is specific to one (or more) models only, clear reference to the relevant model type(s) will be made.

NOTE: Cloud amplifier models CV2500, CV4250 and CV8125 are NOT covered by this Guide.

CA Series amplifiers - main features

- Output stage can drive 70 V/100 V-line systems directly (transformerless), or low impedance loudspeakers (≥ 4 ohms)
- Output mode selectable per-channel
- Balanced line level inputs
- Per-channel output level controls
- Per-channel rear panel input switches for input routing, high or low impedance operation, 70 V/100 V-line selection and high-pass filter
- Automatic Power Down: <2.5 W power consumption with all channels quiescent
- Remote Power control input
- Global disable of APD function
- Variable speed forced-air cooling
- Thermal protection, overcurrent limiting and DC offset protection
- Switch-on delay for speaker protection during power-up
- Universal PSU – operates from 100 to 240 VAC

Available Options:

- CDI-CA2, CDI-CA4, CDI-CA8 Dante® input cards (providing 2, 4 and 8 Dante input channels respectively)

What's in the Box

Please check the shipping carton for damage before opening. If there is damage, please contact your Cloud agent and the shippers.

The packing carton should contain the following items:

- Cloud CA Series amplifier
- Set of mating plug-in screw-terminal connectors
- Mains cable(s)

Block Diagram

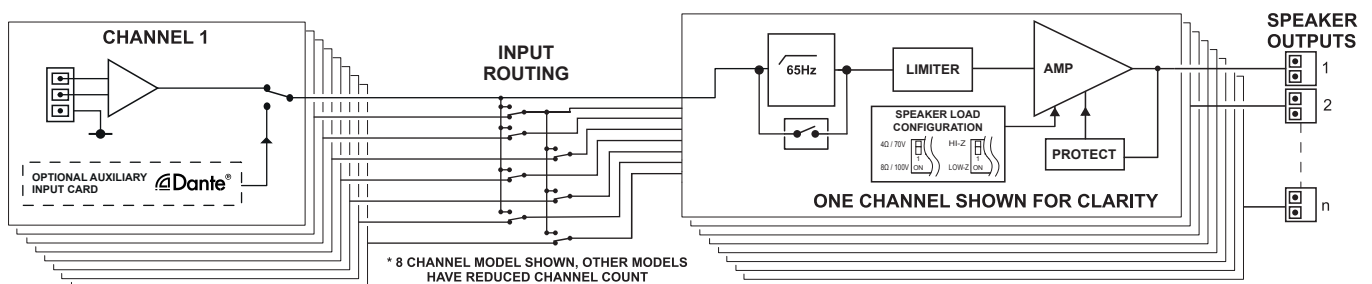

Front Panel Description

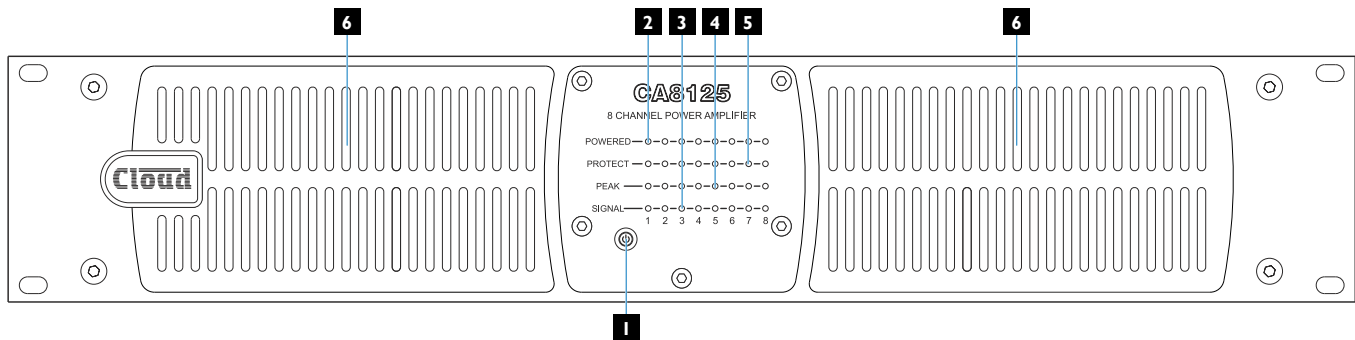

1. **POWER SWITCH** – press to turn the amplifier off: it turns on automatically on initial application of the AC supply. The integral white LED illuminates when the amplifier is powered, either in its active state or in Automatic Power Down (APD) mode.

Each amplifier channel has four LEDs on the front panel, which function as follows:

2. **POWERED** (green) – illuminates when the channel is active, i.e., it has been “woken up” when the output signal level exceeds -65 dB relative to maximum output level (typical threshold: may vary with programme type).
3. **SIGNAL** (green) – illuminates when the output signal level from the amplifier channel is at least $2.5 V_{rms}$.
4. **PEAK** (yellow) – illuminates when the channel’s limiter is active, i.e., reducing gain.
5. **PROTECT** (red) – indicates a fault condition. It illuminates when the power amplifier stage is shut down by the internal protection circuitry, which will occur if excessive current or DC is detected at the output terminals, or if the internal temperature becomes too high. Over-current or DC fault conditions can be cleared by removing the AC power supply for a few seconds, but when the cause is over-temperature, the amplifier will remain in its protected state until the temperature drops (which will generally occur if the input signal is reduced).
6. Ventilation intakes – these should always be unobstructed when the amplifier is in use.

Rear Panel Description

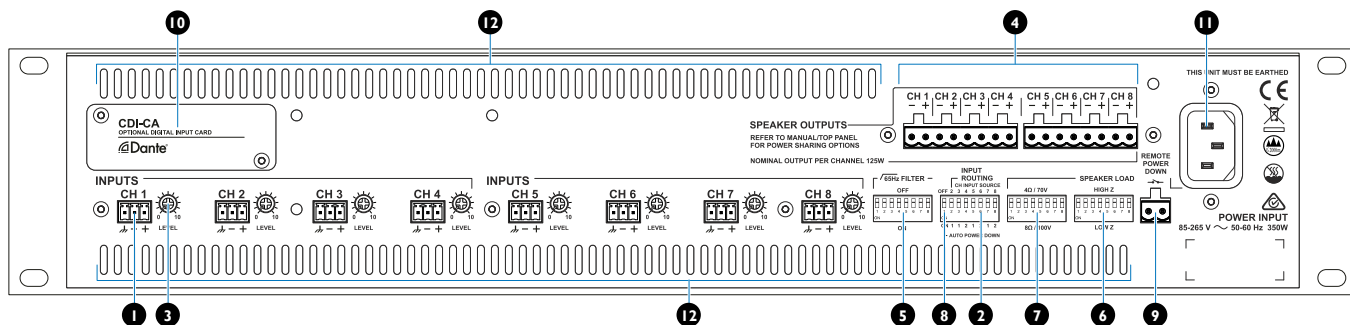

Model CA8125 illustrated: Models CA6160, CA4250 and CA2500 differ only in the number of channels and DIP switch sizes

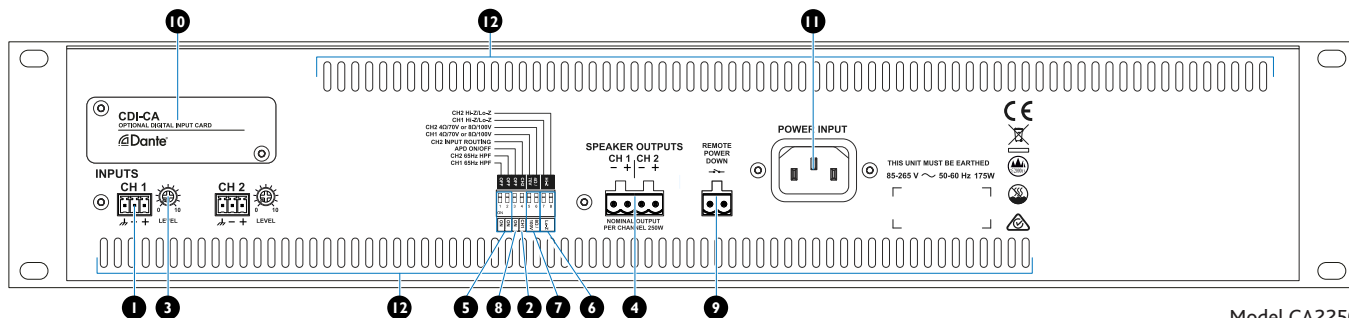

Model CA2250

1. **INPUTS CH 1 ... CH n** – one 3-pin, 3.5 mm-pitch screw-terminal connector per amplifier channel. The inputs are balanced. Connect the audio sources here.
2. **INPUT ROUTING** – a 2-, 4-, 6- or 8-way DIP switch depending on model; exception is Model CA2250 which uses SW4 (CH2 INPUT ROUTING) of the single 8-pole DIP switch. The factory default setting is with all switch sections up: in this state each amplifier channel will be fed by the same-numbered input connector. See page 13 for full description of function. Note that section SW1 on Models CA2500/4250/6160/8125 has a different purpose.
3. **LEVEL** – one recessed preset-type control per channel: adjusts the output level of the channel.
4. **SPEAKER OUTPUTS** – one 2-pin, 5 mm-pitch screw-terminal connector per amplifier channel. Connect the feeds to the loudspeaker systems here. Note that the same connectors are used for both low impedance and high impedance (70/100 V-line) operation.
5. **65Hz FILTER** – a 2-, 4-, 6- or 8-way DIP switch depending on model; exception is Model CA2250 which use SW1 and SW2 (CH1/CH2 65Hz HPF) of the single 8-pole DIP switch. The factory default setting is with all switches down and filters active. The filter frequency is 65 Hz: frequencies below this will be attenuated.
6. **SPEAKER LOAD: HIGH Z/LOW Z** - a 2-, 4-, 6- or 8-way DIP switch depending on model; exception is Model CA2250 which use SW7 and SW8 (CH1/2 Hi-Z/Lo-Z) of the single 8-pole DIP switch. In the HIGH Z position (up), the channel's output stage is configured for driving 70/100 V-line systems. In the LOW Z position (down), the channels output stage is configured to drive low impedance speakers (4 or 8 ohms).
7. **SPEAKER LOAD: 4Ω/70V / 8Ω/100V** – a 2-, 4-, 6- or 8-way DIP switch depending on model; exception is Model CA2250 which uses SW5 and SW6 (CH1/CH2 4Ω/70v or 8Ω/100V) of the single 8-pole DIP switch. The function of these switches depend on the setting of the HIGH Z/LOW Z switch [6]. In high impedance mode, the switches configure the channel's output stage for either 70 V-line (up) or 100 V-line (down) operation. In low impedance mode, the switches configure the channel's output stage for either a minimum load of four ohms (up) or a minimum load of eight ohms (down).
8. **AUTO POWER DOWN ON/OFF** - set this switch to ON (down) to enable the amplifier's Automatic Power Down (APD) function. When enabled, channels will mute after 15 minutes if no input signal is detected; if no signal is detected for 25 minutes, the channels will enter Standby Mode. Note that the APD ON/OFF switch uses the first pole of the INPUT ROUTING DIP switch bank on Models CA2500, CA4250, CA6160 and CA8125; on Model CA2250 it uses SW3 of the single 8-pole DIP switch (APD ON/OFF).
9. **REMOTE POWER DOWN** – a 2-pin, 5 mm-pitch screw-terminal connector allowing remote control of the amplifier's Automatic Power Down (APD) function. A contact closure at this connector will force APD, placing the amplifier in Standby Mode, resulting in low power consumption. Note that the **REMOTE POWER DOWN** input is always operative, i.e., regardless of the setting of the **AUTO POWER DOWN** switch 8.
10. **Expansion bay** – for retrofitting an optional Dante® input card, Part Nos.: CDI-CA2 (2 channels), CDI-CA4 (4 channels) or CDI-CA8 (8 channels).
11. **AC input** – standard IEC receptacle. Use the AC power cable supplied with the amplifier.
12. **Ventilation exhausts** - these should always be unobstructed when the amplifier is in use.

Installation

Mechanical

The amplifiers are designed to be mounted in a standard 19" equipment rack. The front panel is fitted with rackmount ears for this purpose. All models require 2U of vertical rack space. See notes below regarding spacing and ventilation.

Due to the units' weight, the use of rack side rails is recommended.

Ventilation

CA Series amplifiers are force cooled by an internal, thermostatically-controlled fan: temperature is sensed within the amplifiers' power output modules. The fan is inoperative at temperatures below 45 °C. Above this temperature its speed is determined by the hottest amplifier module and increases proportionately to a maximum speed when the highest module temperature reaches 56 °C. Note that the amplifier protection circuitry will operate at internal temperatures of 75 °C or above: see Amplifier Protection for more details.

Always allow adequate space around the amplifier to allow a free flow of air through the unit. Ensure that cable bundles or other items do not obstruct any vents. The airflow intake is at the front panel (filtered), with exits in the rear and left-hand side panels. It is recommended not to mix CA Series amplifiers with other equipment employing forced-air cooling which acts in the opposite direction within the same rack.

CA Series amplifiers have been designed to operate in an ambient temperature range of 0 °C to 35 °C. While satisfactory operation outside of this recommended temperature range may be achievable in a particular installation, no guarantee can be given regarding full adherence to the performance specifications (see the Appendix section of this manual).

Installers should always endeavour to fit the CA Series amplifier in a location where the recommended temperature range is not exceeded.

Power requirements and turning the amplifier on and off

Connect the CA Series amplifier to AC mains using the supplied IEC cable. The amplifier will operate on supply voltages from 85 to 265 V, 50 or 60 Hz.

The amplifier will automatically power-up as soon as external power is applied; this ensures that it restarts correctly if the AC supply is interrupted. The front panel **POWERED** **2**, **PROTECT** **5** and **PEAK** **4** LEDs will illuminate briefly while internal diagnostics are conducted. The white LED integral with the power button will remain on after this sequence. The amplifier always powers-up into its active state, even if APD mode is enabled.

CA Series amplifiers are highly energy efficient and have a two-stage Automatic Power Down (APD) feature. This puts odd and even channel groups into a reduced-power Mute state when no input signal to a group member channel has been detected for 15 minutes. (Actual power

figures are model-dependent: see Specifications.) This state is indicated by the simultaneous illumination of the **POWERED**, **PROTECT** and **PEAK** LEDs for the relevant channels. If no input signal has been detected for 25 minutes the relevant channels will then enter a low-power Standby Mode. In this mode, only the white LED in the power button will be illuminated. The power consumption in Standby Mode is <2.5 W for all models. Note that APD mode may be disabled by setting the rear panel **AUTO POWER DOWN** switch [8] to OFF (up).

The front panel power button  **1** is a "soft" type; press to turn the amplifier off.

Remote Power Down

The amplifier may be "forced" into Standby Mode applying a short-circuit to the rear panel **REMOTE POWER DOWN** connector **9**. The connector is a 2-pin, 5 mm-pitch screw-terminal type. The amplifier will "wake up" when the short-circuit is removed: wake-up time is typically 500 ms. This function can be useful in shutting down e.g., visitor attractions at museums and theme parks. **REMOTE POWER DOWN** is operational regardless of the setting of the **AUTO POWER DOWN** switch **8**.

Amplifier Protection

CA Series amplifiers' output stages incorporate comprehensive protection circuitry to prevent damage to loudspeakers, the output devices and other components in the event of a fault condition.

The voltage and current at the output terminals of each channel is constantly monitored and the channel will enter Protection Mode and shut down if either DC or excessive current is detected. In this case, the relevant front panel **PROTECT** LED will illuminate. Power-cycling the amplifier by removing the IEC power connector and replacing it after 5 seconds will normally clear the fault condition, but if the **PROTECT** LED remains lit after the boot sequence, the amplifier may have developed a fault, and should be serviced.

The internal temperature of the power modules is also constantly monitored, and if the temperature of an output module exceeds 75 °C, the channel will enter Protection Mode and the gain will be reduced by up to 3 dB: the front panel **PROTECT** LED **5** for the relevant channel will illuminate. If the temperature exceeds 85 °C, the protection circuitry will mute all amplifier channels, all **PROTECT** LEDs will be illuminated and all other LEDs off. A thermally-induced protection state is normally an indication that the amplifier channel is being driven too hard, and reducing the input signal level will generally clear the fault.

The protection circuitry is also activated immediately the amplifier is powered on. This is to prevent any voltage spikes due to start-up conditions from damaging the loudspeakers. The protection circuitry automatically times out after a short delay. All **PROTECT** LEDs illuminate at switch-on during the power-on sequence: this is normal.

Power sharing (high impedance output mode only)

Models CA2500/4250/6160/8125:

A fundamental design concept of CA Series amplifiers is the availability of Power Sharing when one or more channels is selected to HIGH Z mode, in order to drive 70/100 V-line loudspeaker systems. The maximum power output capability of all CA Series models except the CA2250 is 1 kW: the maximum power output capability of the CA2250 is 500 W. To use the amplifier to its maximum effectiveness, installers wishing to use the high impedance output mode should have an understanding of how this maximum power figure is shared between channels.

All models except the CA2250 use two separate internal power supplies, each rated at 500 W. The two supplies serve the odd- and even-numbered channels respectively. Each amplifier channel is capable of delivering 500 W, but this figure can only be realised if the other channels in its group (of odd or even-numbered channels) are unused. As other channels in the same group are called upon to deliver power, the maximum power available from any one channel is reduced. If all channels are simultaneously driven with equal input levels, and the **LEVEL** controls are adjusted to the same setting, the maximum, multi-channel power rating of the amplifiers can be stated as follows:

- CA2500: 2 channels, 500 W/ch
- CA4250: 4 channels, 250 W/ch
- CA6160: 6 channels, 160 W/ch
- CA8125: 8 channels, 125 W/ch

The great advantage of the power sharing principle is that it allows installers to use some channels to drive speakers in areas where only low power is needed, and others for areas where more is needed.

It should be apparent that the 2 channel CV2500 is somewhat independent of the power sharing principle, having only one odd and one even channel.

Model CA2250:

Model CA2250 uses a single internal power supply rated at 500 W, which serves both Channel 1 and Channel 2. Power sharing in high impedance mode is similarly available, but only up to a total amplifier output power of 500 W. Each channel is capable of delivering 500 W, but can only do so if the other channel is quiescent. If both channels are simultaneously driven with equal input levels, and the **LEVEL** controls are adjusted to the same setting, the maximum, two-channel power rating of the CA2250 can be stated as follows:

- CA2250: 2 channels, 250 W/ch

NOTE: The principle of Power Sharing only applies to amplifier channels selected to HIGH Z mode – i.e., used with 70/100 V-line loudspeaker systems. For channels selected to LOW Z mode, the minimum speaker loads – 4 or 8 ohms – must be observed. In these cases, the power capability of the channel should be taken from the table below when calculating the remaining power available for other channels:

MODEL	CHANNELS	POWER (low impedance mode)
CA2250	2	2 X 250 W
CA2500	2	2 X 500 W
CA4250	4	4 X 250 W
CA6160	6	6 X 160 W
CA8125	8	8 x 125 W

Connections and Adjustments

Inputs

Each amplifier channel has an electronically-balanced input on a 3-pin, 3.5 mm-pitch screw terminal connector ❶. Twin-core screened cable should be used when driving the amplifier inputs from a device with a balanced output. Single-core screened cable can be used when connecting to an unbalanced source.

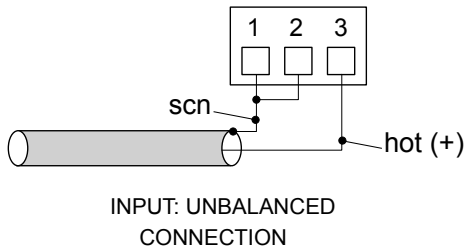
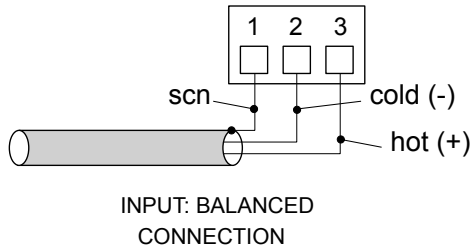

Input Routing

In common with other Cloud power amplifiers, each amplifier channel can either be fed with a signal from its own input (the factory default setting), or with the signal feeding another channel. This allows the same input signal to feed several channels without the need for input connectors to be wired in parallel. CA Series amplifiers with fewer channels are obviously restricted in the range of routing options available in comparison with models with more channels.

The rear panel **INPUT ROUTING** DIP switches ❷ are used to select input source for each channel, except Channel 1. Models CA2500, CA4250, CA6160 and CA8125 have a dedicated DIP switch bank for input routing: Model CA2250 uses SW4 of the single 8-pole DIP switch. The factory default setting is with all input routing switches UP, which connects the input to each amplifier channel to the same-numbered input connector, as indicated on the upper row of numbers. Setting a switch DOWN parallels the input of that amplifier channel with the input of the amplifier channel indicated below the switch.

Notes:

- Pole 1 of the DIP switch on Models CA2500/4250/1610/8125 is not concerned with input routing.
- SW4 of the single 8-pole DIP on Models CA2250 selects the input source for Channel 2 only

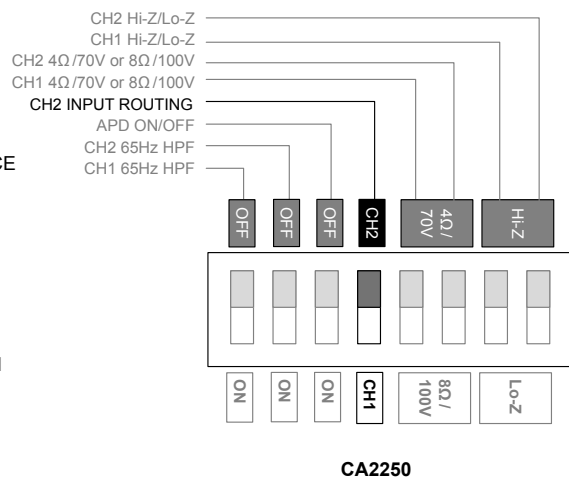
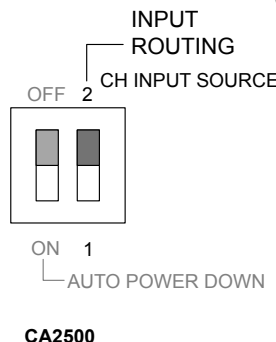
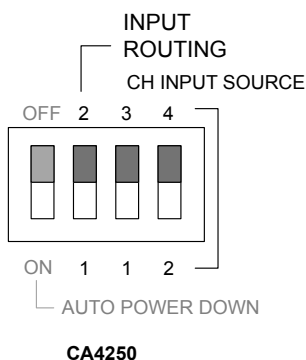
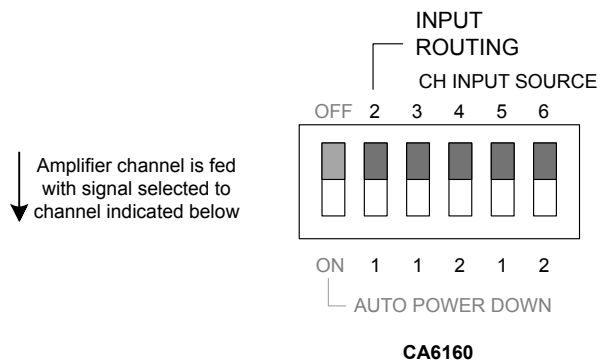
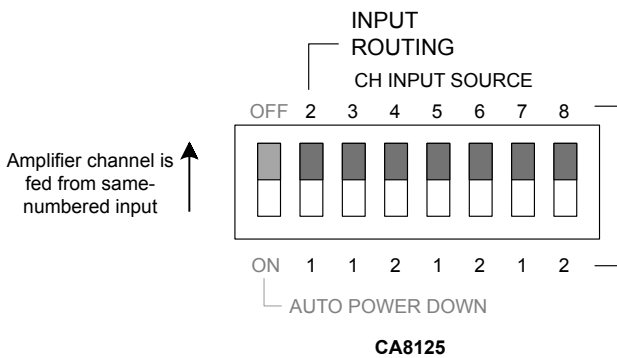

The input routing switches operate in the manner shown in the schematics below.

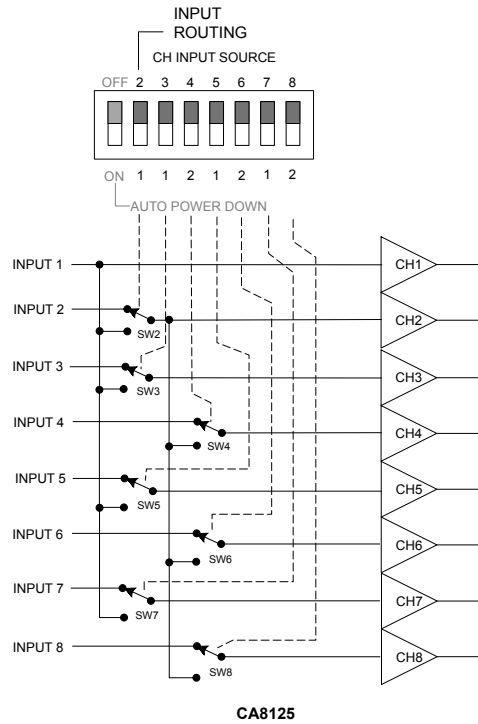
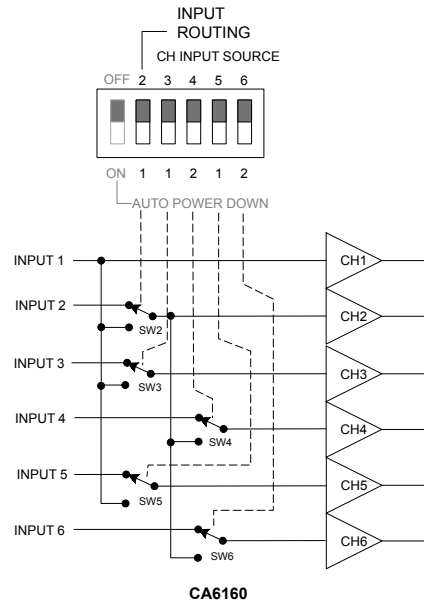
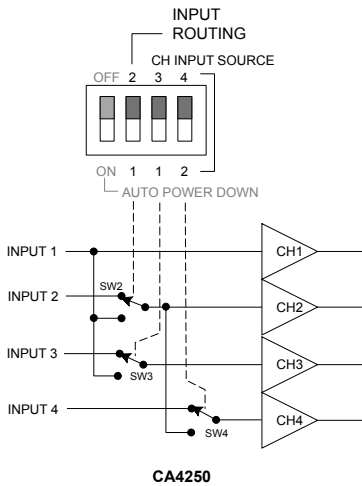
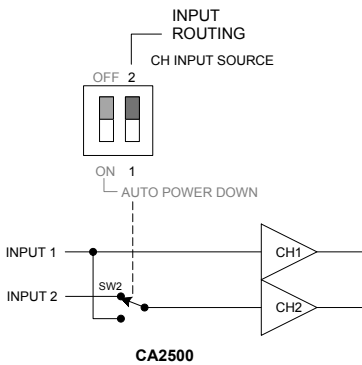
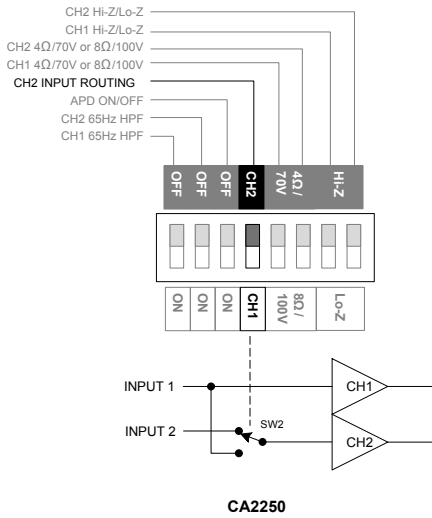

For all CA Series models, the routing options may be summarised as follows:

- all amplifier channels may be sourced by the same-numbered input
- Channel 2 may be sourced from either Input 1 or Input 2
- odd-numbered channels from Channel 3 upwards may alternatively be sourced from Input 1
- even-numbered channels from Channel 4 upwards may alternatively be sourced with whichever input is selected for Channel 2

Outputs

The speaker output connector for each amplifier channel is a 2-pin, 5 mm-pitch screw-terminal type ④. The plug-in connectors are suitable for cable cores up to 2.5 mm².

Connect as shown below:

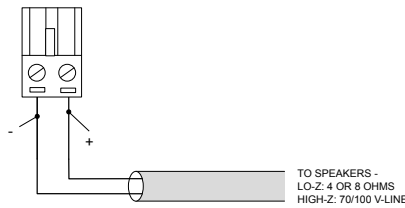

⚠ Never make connections to the output terminals while the amplifier is powered.

The output stages of CA Series amplifiers can be configured to drive either high impedance loudspeaker distribution systems (70 V-line or 100 V-line), or low impedance loudspeakers (4 ohms or greater). The selection of output mode is made independently for each amplifier channel with the rear panel **SPEAKER LOAD HIGH Z/LOW Z** DIP switch ⑥. On Models CA2500, CA4250, CA6160 and CA8125, this is a dedicated 2-, 4-, 6- or 8-pole switch: on Model CA2250, output mode selection is made using poles SW7 and SW8 of the single 8-pole DIP switch. (The first example shown below is for the 4-channel CA4250; the principle is identical across the range.)

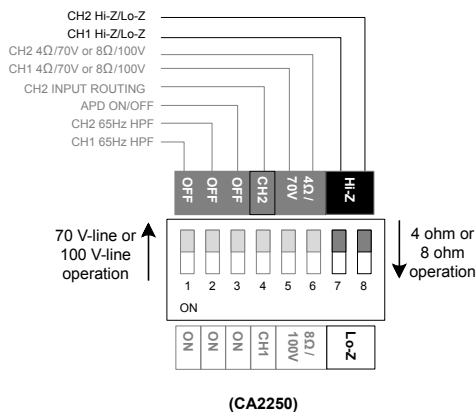
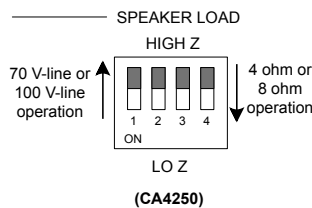

The output mode may be set independently for each channel. Set the switch UP for high impedance (70/100 V-line) operation and DOWN for low impedance operation.

IMPORTANT: CA Series amplifier channels normally operate in a bridge configuration in both low and high-impedance modes: pairs of channels cannot be bridged externally to obtain a higher power output.

70/100 V-line operation

In high impedance mode, CA Series amplifiers can drive either 100 V-line or 70 V-line loudspeaker distribution systems directly. The system voltage is set by the rear panel **SPEAKER LOAD 4Ω/70V / 8Ω/100V** DIP switch ⑦. On Models CA2500, CA4250, CA6160 and CA8125, this is a dedicated 2-, 4-, 6- or 8-pole switch: on Model CA2250, output mode selection is made using poles SW5 and SW6 of the single 8-pole DIP switch. (The first example shown below is for the 4-channel CA4250; the principle is identical across the range.)

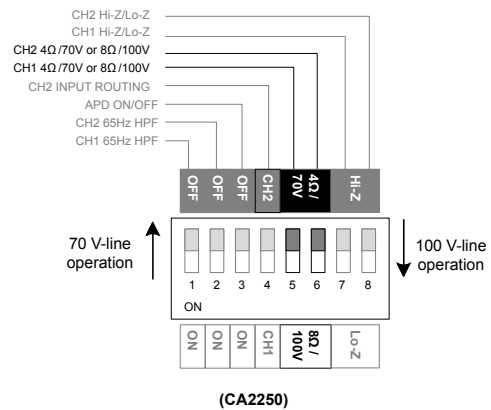
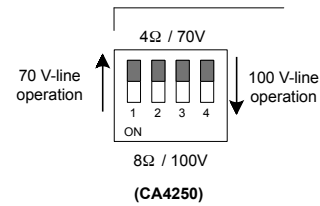

The voltage may be set independently for each channel. Set the switch UP for 70 V line operation and DOWN for 100 V line operation.

In high impedance (70/100 V-line) mode, the transformerless output stage of each amplifier channel is designed to deliver a maximum of 500 W, as long as the other channels in the same odd- or even-numbered group (i.e., using the same internal power supply) are unloaded. When using multiple channels of a CA2500, CA4250, CA6160 or CA8125 amplifier, installers should ensure that the total loading on the odd-numbered channels does not exceed 500 W, and the total loading on the even-numbered channels, does not exceed 500 W. Model CA2250 uses a single power supply, and the total loading of both channels combined must not exceed 500 W.

The wattage loading for each channel, can be calculated by adding together the tap wattage settings for all speakers connected to that channel.

High Pass Filters

Most transformers fitted to 70/100 V-line speakers exhibit core saturation when fed with high-level signals at low frequencies. Transformer saturation creates unpleasant distortion and stresses the system. To counteract this, a correctly configured high pass filter is an essential part of any line distribution system. CA Series amplifiers have a high pass filter in each channel, selectable via the **65Hz FILTER** DIP switch on the rear panel **5**. On Models CA2500, CA4250, CA6160 and CA8125, this is a dedicated 2-, 4-, 6- or 8-pole switch: on Model CA2250, output mode selection is made using poles SW1 and SW2 of the single 8-pole DIP switch. (The first example shown below is for the 4-channel CA4250; the principle is identical across the range.)

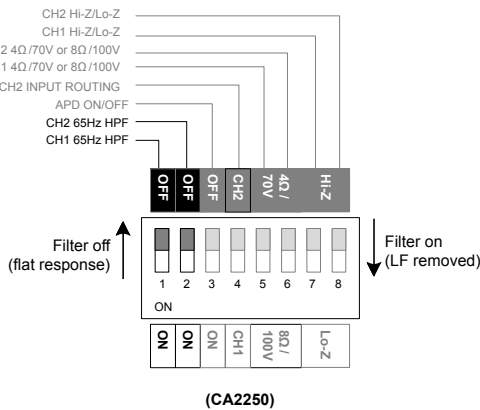
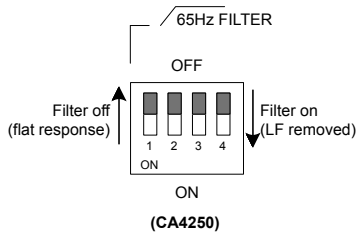

Low impedance operation

In low-impedance mode, the output stage may be optimised for use with loads of either four or eight ohms with the **SPEAKER LOAD 4 Ω/70V / 8 Ω/100V** DIP switch **7**. In the **4 Ω** setting (switch UP) the load impedance must not be less than four ohms, and in the **8 Ω** setting (switch DOWN) the load impedance must not be less than eight ohms. However, higher impedances may be driven in both cases, though the maximum power output of the amplifier channel will not be available.

Check the impedance of the loudspeakers to be driven by the amplifier; if using multiple loudspeakers, employ series/parallel wiring as appropriate to ensure the combined impedance is not less than the impedance set with switch **7**.

The power capability of an amplifier in low impedance mode should be taken to be the nominal channel power level for the particular amplifier model, assuming the load impedance matches that set by switch **7**. For example, a low-impedance channel of a CA8125 should be considered to be loading its power supply with 125W.

Level Control

Control of audio level in each channel is provided by the rear panel preset rotary **LEVEL** control **3**. It should be appreciated that this adjusts the signal level feeding the amplifier power stage and is thus essentially an output level control, not an input level or sensitivity control. The preset should be adjusted using a trim tool or small screwdriver. Zero output is obtained with the control fully anti-clockwise. Full output level is with the control fully clockwise; at this setting the maximum output power (70 V_{rms} or 100 V_{rms} in high impedance mode) will be produced for an input signal level of 0.775 V_{rms} (0 dBu).

We recommend that the level for each channel should be set after installation is complete by commencing with the **LEVEL** controls at minimum. Installers should ensure that adequate, but not excessive sound levels are achieved with the programme material that will be used in practice.

Technical Specifications

Performance		All Models					
Output Power:		CA2250: total output power 500 W, both channels CA2500/CA4250/CA6160/CA8125: total output power 1 kW, all channels ¹					
Outputs:		Low-impedance: 4 ohms or 8 ohms (selectable) High-impedance: 70 V or 100 V (rms)					
Frequency Response:		20 Hz to 20 kHz, +0 dB/-1 dB					
High Pass Filter:		-3 dB @ 65 Hz via rear panel switches					
Distortion:		0.019%THD+N @1 kHz, 1 dB below rated output					
Noise:		-94 dBr, 22 Hz to 22 kHz, relative to full power					
Crosstalk:		Ch1 to Ch2: < -98 dB @1 kHz, -79 dB @10 kHz Other channel combinations: -107 dB @1 kHz, -98 dB @10 kHz (typical)					
Inputs							
Connectors		3-pole 3.5 mm-pitch plug-in screw-terminal connectors					
Sensitivity		0 dBu (0.775 V _{rms})					
Input Impedance		10 kohms (balanced); 5 kohms (unbalanced)					
General							
Output connectors		2-pole 5 mm-pitch plug-in screw-terminal connectors					
Power input		85 to 265 V AC, 50 to 60 Hz					
Mains protection		Internal fuses: CA2250: 1 x 250 V fuse, 20 x 5 mm, rating T4AH CA2500, CA4250, CA6160, CA8125: 2 x 250 V fuses, 20 x 5 mm, rating T4AH					
Normal operating temperature		0 °C to 35 °C (Note performance and specifications cannot be guaranteed outside this range)					
Power Consumption		CA2250	CA2500	CA4250	CA6160	CA8125	
	Standby & APD ²	0.795 W (12.43 VA)	1.919 W (24.29 VA)	1.925 W (23.77 VA)	2.284 W (23.55 VA)	2.353 W (23.77 VA)	
	Mute ³	11.24 W (21.09 VA)	17.87 W (36.85 VA)	22.37 W (41.97 VA)	26.87 W (48.15 VA)	25.91 W (48.7 VA)	
	Idle ⁴	17.07 W (28.13 VA)	24.33 W (43.6 VA)	33.72 W (53.87 VA)	43.45 W (66.54 VA)	53.8 W (78.77 VA)	
	1/8th power ⁵	88.33 W (105.8 VA)	165.1 W (193.5 VA)	170.0 W (192.3 VA)	170.2 W (205.8 VA)	183.5 W (219.8 VA)	
	1/3rd power ⁶	200.9 W (213.5 VA)	388.0 W (415.4 VA)	391.0 W (416.0 VA)	378.5 W (403.5 VA)	387.5 W (411.8 VA)	
Heat loss	Standby & APD ²	2.9 kJ/hr (2.7 BTU/hr)	6.9 kJ/hr (6.6 BTU/hr)	6.9 kJ/hr (6.6 BTU/hr)	8.2 kJ/hr (7.8 BTU/hr)	8.5 kJ/hr (8.0 BTU/hr)	
	Mute ³	40.5 kJ/hr (38.4 BTU/hr)	64.3 kJ/hr (61.0 BTU/hr)	80.5 kJ/hr (76.4 BTU/hr)	96.7 kJ/hr (91.7 BTU/hr)	93.3 kJ/hr (88.5 BTU/hr)	
	Idle ⁴	61.5 kJ/hr (58.3 BTU/hr)	87.6 kJ/hr (83.1 BTU/hr)	121.4 kJ/hr (115.1 BTU/hr)	156.4 kJ/hr (148.3 BTU/hr)	193.7 kJ/hr (183.7 BTU/hr)	
	1/8th power ⁵	91.7 kJ/hr (87.0 BTU/hr)	108.3 kJ/hr (102.7 BTU/hr)	164.9 kJ/hr (156.4 BTU/hr)	179.5 kJ/hr (170.2 BTU/hr)	211.0 kJ/hr (200.1 BTU/hr)	
	1/3rd power ⁶	122.5 kJ/hr (116.1 BTU/hr)	197.3 kJ/hr (187.1 BTU/hr)	210.0 kJ/hr (199.1 BTU/hr)	211.3 kJ/hr (200.4 BTU/hr)	242.7 kJ/hr (230.2 BTU/hr)	
Amplifier Protection		Overcurrent DC Thermal monitoring Switch-on delay					
Status Indicators		Power applied, Protection active, Signal peak, and Signal present					
Cooling		Variable speed fan					
Dimensions (W x H x D)	Net	CA2250: 482.6 mm x 88 mm x 231.3 mm (19 in x 3.46 in x 9.11 in) CA2500, CA4250, CA6160, CA8125: 482.6 mm x 88 mm x 381.8 mm (19 in x 3.46 in x 15.03 in)					
	Shipping	CA2250: tbc CA2500, CA4250, CA6160, CA8125: 606 mm x 164 mm x 558 mm (23.9 in x 6.5 in x 22 in)					
Weight		CA2250	CA2500	CA4250	CA6160	CA8125	
	Net	4.50 kg (10.1 lb)	6.75 kg (15.1 lb)	7.10 kg (15.9 lb)	7.55 kg (16.9lb)	7.95 kg (17.8 lb)	
	Shipping	tbc	8.75 kg (19.6 lb)	9.10 kg (20.4 lb)	9.55 kg (21.4 lb)	9.95 kg (22.3 lb)	

NOTES

1. Odd- and even-numbered channel groups can deliver up to 500 W simultaneously (CA2250 excepted), but in models with more than two channels, the available power is reduced proportionately when any channel is delivering more than its nominal rating. On Model CA2250, the maximum power of 500 W is shared between the two channels as required.

Notes re Power Consumption and Heat Loss measurements:
All measurements at 230 VAC 50 Hz power input

2. Standby: amplifier in Standby and APD states (i.e., after 25 mins of no input)
3. Mute: amplifier in Mute state (i.e., after 15 mins of no input)
4. Idle: amplifier not in standby state, but no audio output
5. 1/8th power: constant sound level at 1/8 of the rated output power (audio mainly clean, only occasional clipping)
6. 1/3rd power: constant sound level at 1/3 of the rated output power (audio beginning to become compressed, limited or heavily clipped)

www.cloud.co.uk



www.cloudusa.pro